

Design and Implementation a System for Monitoring the COVID19 Patients Based on the Internet of Thing Applications

<https://doi.org/10.3991/ijes.v10i02.27547>

Nabaa Ali Jasim, Haider TH. Salim ALRikabi^(✉)
Wasit University, Wasit, Iraq
hdhiyab@uowasit.edu.iq

Abstract—The Corona Virus (COVID-19) was spread in about 215 countries in 2019. The number of people affected by the epidemic has increased dramatically. Iraq is one of the countries affected by the Coronavirus. Hundreds of Iraqi doctors have died because they contact directly with patients. One of the most serious challenges is the high rate of conduction through contact with people infected with this virus. The impact of the coronavirus can be reduced by using one of the advanced technology methods. The internet of things (IoT) is one of these applications. This paper shows that the role of smart surveillance in reducing the risks of covid-19. To avoid face-to-face interaction, physical contact, and maintain social distancing, the smart monitor is designed in this paper. It is used to monitor the health parameters that are affected when infected with covid-19, such as heart rate, oxygen level, blood pressure, and body temperature in real-time and remotely. This will reduce the workload, workload on the medical staff, and reduce the infection with the covid-19.

Keywords—Internet of Thing (IoT), COVID-19, Health system, EPS32, Raspberry Pi, MQTT

1 Introduction

Technological development always plays an important and essential role to provide a suitable environment for living [1]. The goal of any human being, regardless of this age, gender, location, or health condition is an independent, comfortable, and healthy life. However, obstacles arise due to age, disease, medications, epidemic, and other conditions. The spreading of coronavirus since 2019, all the characteristic of daily life has been changed. In addition, the economic side has been affected too. Moreover, the main cause of the infection is not known, whether by spray, touch, or air. Although the vaccine has not been known to cure this epidemic until now, we can reduce the impact of the epidemic by using one of the advanced technologies. In this paper, we used smart monitor technology to reduce the effect of covid-19 based on the internet of things (IoT). The system of health checking plays a very essential role in reducing bodily contact, hospitalization, discussion time, waiting list, the cost for the patient, and reducing the load of the medical staff. Therefore, developments in data and communication

technologies provide contacting everywhere and anytime a valued contribution to the progress of the health care system and distant persistent checking [2, 3]. Barton, Duval et al. proposed remote smart home healthcare enhance system (ShHeS) for monitoring patients' health status and receiving doctors' instructions while staying at home [4]. In addition, the doctors can also give a diagnosis of illnesses by using the data collected remotely from the patients. The system made dual real-time communication between patients and doctors by implementing the application of an Android-based mobile that interrelates with the application of web-based. They integrated the sensors into a system automatically capturing patients' physiological health parameters. The system plays a dual role in monitoring health and controlling basic home applications remotely. So, the people can delight in their communal life while still managing and monitoring their health, especially during the era of the epidemic [5]. Bowen and Yanjing proposed an adaptive system by depending on the diagram implanting technique during the state representation and reinforcement learning in the training phase [6, 7]. The results show that the system can reduce the epidemiological reproducing rate of the infection beneficially by relying on a pair of real-life datasets. Advanced technology has the potential to help the detection of COVID19 situations at the initial point [8, 9]. In addition, Allam, Jones, Costa, and Peixoto studied the desired importance system of smart cities for falling the impact of the coronavirus [10, 11]. They discussed the uses of all smart city technologies broadly to alleviate the risks of covid-19 [12, 13]. Where they showed the importance of location technology in tracking infected people. Moreover, some researchers discussed the use of drones and robot technologies to work as medical staff and useful for other important facilities [14–16]. In addition, they show the importance of smart health care to take care of the injured and treat them without any contact [17]. As we explained, using the internet of things (IoT) will improve health care and also enables remote monitoring of patients, especially smart city technology covid-19 patients during their quarantine [18–21]. Thus, doctors can display patients from their clinics, propose prescription, and view measured energetic health restrictions for distant diagnosis. In this paper, an intelligent health support system has been designed to monitor the covid-19 patients remotely during their quarantine. The parameters, such as temperature, plus, oxygen, and blood pressure which are affected by COVID19 can be diagnosed remotely by using portable sensors for medical diagnosis and prescriptions [22–24].

2 Project requirements

2.1 Sensors

In this paper, there are two sensors used to collect the data from the patients.

2.2 MLX90614

It is non-contact temperature reading, the smart metering thermometer, and it has a lot of applications like Windshield defogging, Livestock monitoring, and Movement

detection, etc. In this paper, it is used to read the body and room temperature [25–27]. It is distinguished by its small size, low cost, and ease of integration.

2.3 AX30100

It is an integrated solution of pulse oximetry and heart rate detect sensor. It consists of LEDs, a photo-detector, optimized optics, and low-noise analog signal processing.

2.4 Microcontroller

ESP32 microcontroller is used with a node sensor to receive the data from the sensor and send it to the server. The ESP32 is a dominant 32-bit microcontroller, and it combined Wi-Fi, a full TCP/IP stack for internet connection, and Bluetooth 4.2. Due to the low cost combined with limitless power, and the chance to connect the ESP32 to many other electronic devices the microcontroller is well suitable for IoT projects [28–31].

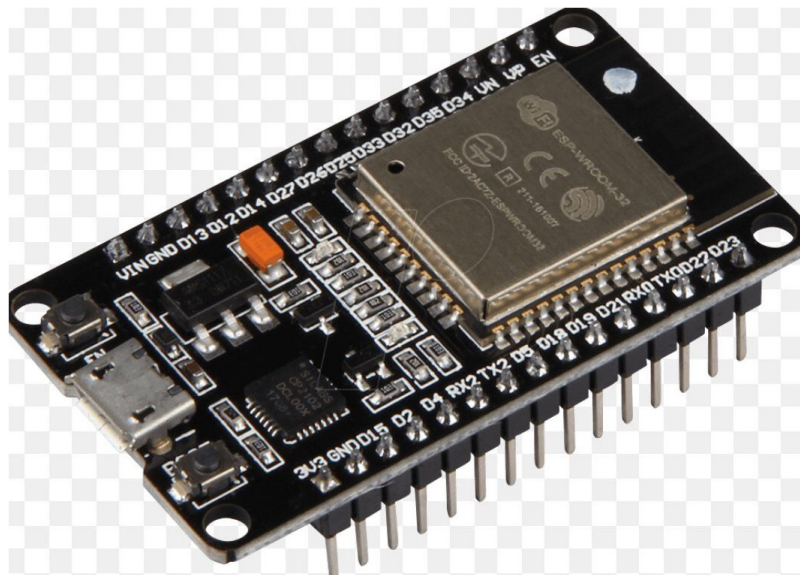

Fig. 1. It show the ESP32 controller

2.5 Server

The server which is used is Raspberry Pi 3 Model B+. The Raspberry pi 3 variety boastful a 64-bit. The quad-core processor organization at 1.4GHz, dual-band 2.4GHz and 5GHz wireless LAN, Bluetooth 4.2/BLE, faster Ethernet, and PoE ability by an unconnected PoE HAT [32–34].



Fig. 2. Show the raspberry pi 3

2.6 Communication

To send data by **Wi-Fi**, the **MQTT** protocol (Message Queuing Telemetry Transport) is used. MQTT protocol is a light messaging transport protocol based on distributing/contribute messaging and works on top of TCP/IP [35, 36].

2.7 Logic level converter

It is represented by a minor device that safely steps up 3.3v to 5v and steps down 5v signals to 3.3v at the same time, also it works with 2.8v and 1.8v devices.

2.8 Application

The application will be able to be retrieved through most tools like computers, phones, and tablets, individualistically of their operating system.

3 Proposed work

Health monitoring has become a reality. With the start of the internet of things (IoT), it became possible to monitor the patients, write prescriptions, and consult remotely. Medical equipment such as sensors, precise control, and actuators have become intelligent. As a result, it became easier to access patients' data to doctors and organize their health remotely. In addition, patients' health standards can be measured and

transferred to the database for treatment diagnosis. Thus, people infected with the coronavirus or who contact infected patients can be quarantined at home or hospital and monitored remotely without any physical contact. In this paper, a health monitoring system is proposed for the patient during their quarantine. The function of our proposed system is to monitor and record the patient's physiological data such as body temperature, room temperature, pulse rate, and blood oxygenation. When this data is collected by sensors and then transferred via Wi-Fi to the server. The data can be displayed on the server by using a mobile, iPad, or laptop in the form of curves. The main goal of this system is that to reduce the crowded groups of patient's people in hospitals and reduce the transmission of infection from the patients who are infected by empedic to the medical staff. As well as it provides a comfortable life for the patient during quarantine or home quarantine. In this paper, we used health parameters such as body temperature, room temperature, blood oxygenation, and heart rate as a focus of our design.

3.1 System construction

Figure 3 illustrates the engineering design of the suggested system. This construction includes sensors, microcontroller, Wi-Fi network, server, and mobile or laptop. The scenario of this system is, the MLX90614 sensor measures both room temperature and body temperature, and the MAX30100 sensor measure both heart rate and blood oxygenation. The sensors have connected to a logic level converter, as we can see clearly in Figure 4. Because the sensors transmit their data at 5v, while the ESP32 works at 3.3v, a logic level converter is used to shift the signal from 5v to 3.3v or from 3.3v to 5v. So, ESP32 can read the data from the sensors.

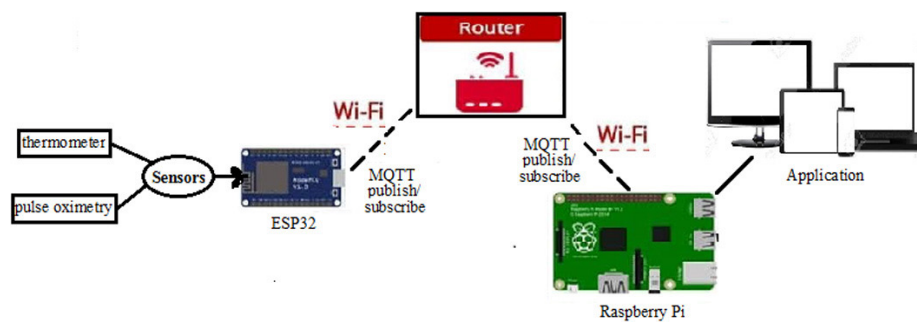

Fig. 3. It shows the system components

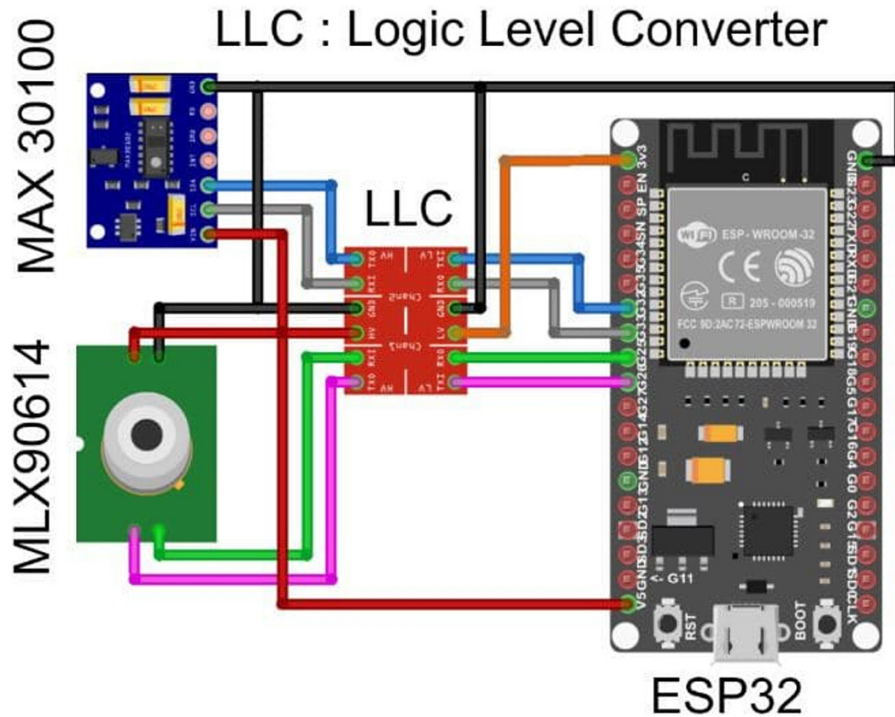

Fig. 4. It shows the diagram circuit of the proposed system

The readings obtained from the sensors will be collected in the ESP32 microcontroller connected with the sensors node. Then, the data will be sent from the ESP32 microcontroller to the server via the internet using the MQTT protocol. The server is Raspberry pi, where the data is stored and processed in the database, then extracts the minimum, maximum, and average rate from the data in the form of curves over time. Through a mobile phone, laptop, or iPad. The doctor can monitor the patient’s status by entering the IP address of the server on the website. Through these curves, the doctor can know the status of quarantined covid-19 patients. By this, we can reduce the transmission of the covid-19 infection to the medical staff.

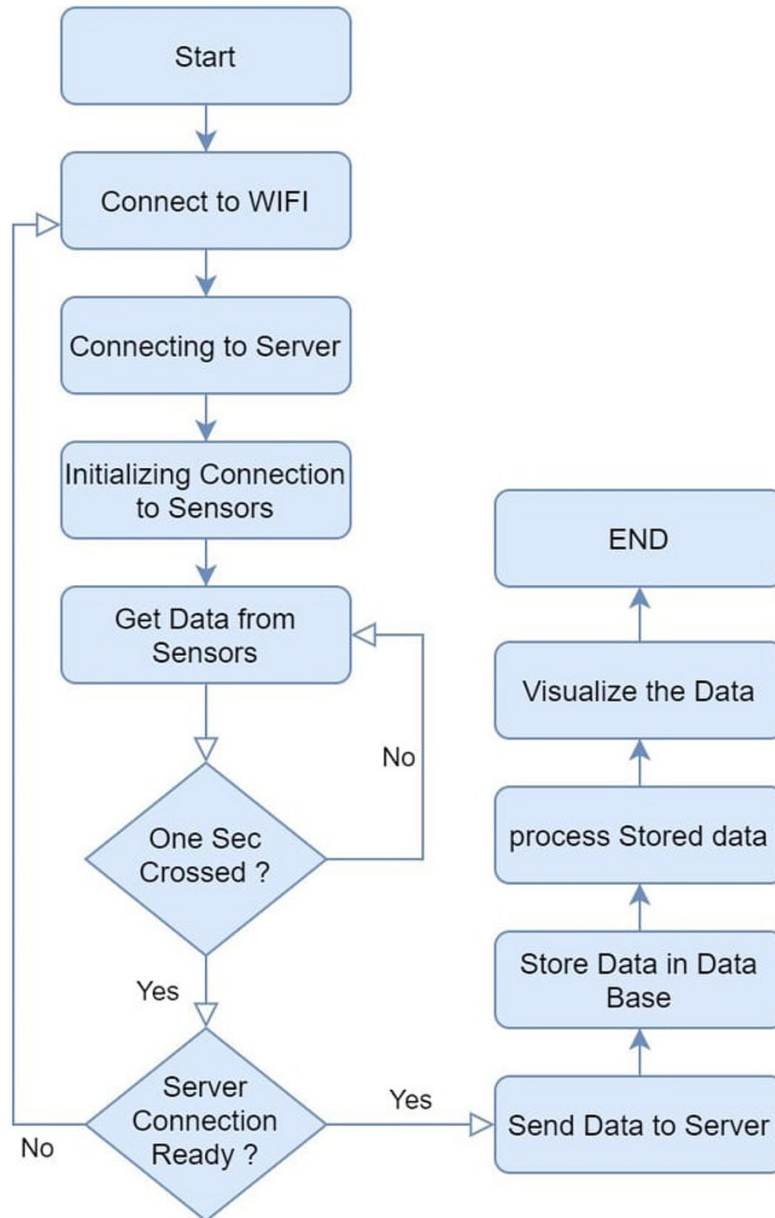

Fig. 5. It shows the flow chart of the proposed system

4 Results and discussion

The proposed smart health monitoring system has both patient and physician sides. On the part of the patient, the sensors measure the patient's health standards and collect this data in the microcontroller and send it to the doctor automatically every period of time. On the other part, the doctor can check the results through a mobile phone, display screen, or laptop as soon by entering the IP address of the server on the website. In addition, the doctor can monitor many patients who are infected with covid-19 and view their health standards remotely. In this system, health parameters that are affected by the covid-19, such as body temperature, the oxygen level in the blood, and heart plus rate are monitored. The proposed system extracts these correct parameters from the server in the form of curves over time, as shown in Figure 6.



Fig. 6. It shows the results of the system

Figure 6 shows the correct standards for the covid-19 patient every ten seconds. In addition, it extracts the minimum, maximum, and average rate that the patient reached based on these measurements. The range of time, we can change it from the website interface. In addition, the doctor can view the data for the last minute, day, or month, etc. Thus, the doctor can monitor and see the health standards of the covid-19 patient, know the response rate to the treatment provided, and prescribe drugs if needed. The system is designed for the medical staff to monitor the largest possible number of patients at the same time and remotely without any contact with the patients. This proposed system serves the great purpose of activating a distant checking of covid-19 patients. Also, it is used to protect the medical staff from contact with coronavirus infection.

5 Conclusion

The implementation of the internet of things (IOT) has greatly improved comfortable living, health care, and improved social lifestyle for the people. The monitoring system makes the contact between the patients and doctors easy. In this paper, an intelligent monitoring system was suggested for covid-19 patients. This work has mainly

focused on reducing transmission of coronavirus infection and medical staff through smart monitoring. Also, this system monitors health parameters that are affected when infected with covid-19, such as body temperature, blood oxygen level, and heart rate. The proposed method will have a significant impact on the rate of coronavirus transmission within hospitals. By using this system, it will be no need for a doctor to visit covid-19 patients and check their health status. Through this application, the doctor can know their health standards, which ensure the reduction of infection transmission to the medical staff.

6 References

- [1] G. Aceto, V. Persico, A. J. J. o. N. Pescapé, and C. Applications, “The role of information and communication technologies in healthcare: taxonomies, perspectives, and challenges,” vol. 107, pp. 125–154, 2018. <https://doi.org/10.1016/j.jnca.2018.02.008>
- [2] J. W. Yoon, R. L. Welch, T. Alamin, W. F. Lavelle, I. Cheng, M. Perez-Cruet, L. C. Fielding, R. C. Sasso, R. Linovitz, and K. D. J. I. j. o. s. s. Kim, “Remote virtual spinal evaluation in the era of COVID-19,” vol. 14, no. 3, pp. 433–440, 2020. <https://doi.org/10.14444/7057>
- [3] S. Maalsen, R. J. B. D. Dowling, and Society, “Covid-19 and the accelerating smart home,” vol. 7, no. 2, p. 2053951720938073, 2020. <https://doi.org/10.1177/2053951720938073>
- [4] L. M. Barton, E. J. Duval, E. Stroberg, S. Ghosh, and S. J. A. J. o. C. P. Mukhopadhyay, “Covid-19 autopsies, oklahoma, usa,” vol. 153, no. 6, pp. 725–733, 2020. <https://doi.org/10.1093/ajcp/aqaa062>
- [5] O. Taiwo and A. E. J. I. i. M. U. Ezugwu, “Smart healthcare support for remote patient monitoring during covid-19 quarantine,” vol. 20, p. 100428, 2020. <https://doi.org/10.1016/j.imu.2020.100428>
- [6] B. Wang, Y. Sun, T. Q. Duong, L. D. Nguyen, and L. J. I. A. Hanzo, “Risk-aware identification of highly suspected covid-19 cases in social iot: a joint graph theory and reinforcement learning approach,” vol. 8, pp. 115655–115661, 2020. <https://doi.org/10.1109/ACCESS.2020.3003750>
- [7] M. Al-dabag, H. S. ALRikabi, and R. Al-Nima, “Anticipating atrial fibrillation signal using efficient algorithm,” *International Journal of Online and Biomedical Engineering (iJOE)*, vol. 17, no. 2, pp. 106–120, 2021. <https://doi.org/10.3991/ijoe.v17i02.19183>
- [8] A. Kumar, P. K. Gupta, A. J. D. Srivastava, M. S. C. Research, and Reviews, “A review of modern technologies for tackling COVID-19 pandemic,” 2020. <https://doi.org/10.1016/j.dsx.2020.05.008>
- [9] C. J. Wang, C. Y. Ng, “Response to COVID-19 in Taiwan: big data analytics, new technology, and proactive testing,” vol. 323, no. 14, pp. 1341–1342, 2020. <https://doi.org/10.1001/jama.2020.3151>
- [10] Z. Allam and D. S. Jones, “On the coronavirus (COVID-19) outbreak and the smart city network: universal data sharing standards coupled with artificial intelligence (AI) to benefit urban health monitoring and management,” in *Healthcare*, 2020, vol. 8, no. 1, p. 46: Multi-disciplinary Digital Publishing Institute. <https://doi.org/10.3390/healthcare8010046>
- [11] D. G. Costa and JPeixoto, “COVID-19 pandemic: a review of smart cities initiatives to face new outbreaks,” vol. 2, no. 2, pp. 64–73, 2020. <https://doi.org/10.1049/iet-smc.2020.0044>
- [12] R. Jaiswal, A. Agarwal, and R. J. I. S. C. Negi, “Smart solution for reducing the COVID-19 risk using smart city technology,” vol. 2, no. 2, pp. 82–88, 2020. <https://doi.org/10.1049/iet-smc.2020.0043>

- [13] C. S. Lai, Y. Jia, Z. Dong, D. Wang, Y. Tao, Q. H. Lai, R. T. Wong, A. F. Zobaa, R. Wu, and L. Lai, "A review of technical standards for smart cities," vol. 2, no. 3, pp. 290–310, 2020. <https://doi.org/10.3390/cleantechnol2030019>
- [14] S.-Q. Li, W.-L. Guo, H. Liu, T. Wang, Y.-Y. Zhou, T. Yu, C.-Y. Wang, Y.-M. Yang, N.-S. Zhong, and N.-F. J. E. R. J. Zhang, "Clinical application of an intelligent oropharyngeal swab robot: implication for the COVID-19 pandemic," vol. 56, no. 2, 2020. <https://doi.org/10.1183/13993003.01912-2020>
- [15] S. M. Najeeb, S. M. Ali, "Finding the discriminative frequencies of motor electroencephalography signal using genetic algorithm," *Telkomnika* vol. 19, no. 1, 2020. <https://doi.org/10.12928/telkomnika.v19i1.17884>
- [16] A. S. Abdalrada, O. H. Yahya, A. H. M. Alaidi, N. A. Hussein, H. T. Alrikabi, and T. Al-Quraishi, "A predictive model for liver disease progression based on logistic regression algorithm," *Periodicals of Engineering and Natural Sciences*, Article vol. 7, no. 3, pp. 1255–1264, 2019. <https://doi.org/10.21533/pen.v7i3.667>
- [17] M. I. Pramanik, R. Y. Lau, H. Demirkan, and M. A. K. J. E. S. w. A. Azad, "Smart health: big data enabled health paradigm within smart cities," vol. 87, pp. 370–383, 2017. <https://doi.org/10.1016/j.eswa.2017.06.027>
- [18] R. P. Singh, M. Javaid, A. Haleem, R. J. D. Suman, M. S. C. Research, and Reviews, "Internet of things (IoT) applications to fight against COVID-19 pandemic," 2020. <https://doi.org/10.1016/j.dsx.2020.04.041>
- [19] M. Otoom, N. Otoum, M. A. Alzubaidi, Y. Etoom, R. J. B. S. P. Banihani, and Control, "An IoT-based framework for early identification and monitoring of COVID-19 cases," vol. 62, p. 102149, 2020. <https://doi.org/10.1016/j.bspc.2020.102149>
- [20] M. T. Vafea, E. Atalla, J. Georgakas, F. Shehadeh, E. K. Mylona, M. Kalligeros, E. J. C. Mylonakis, and m. bioengineering, "Emerging technologies for use in the study, diagnosis, and treatment of patients with COVID-19," vol. 13, no. 4, pp. 249–257, 2020. <https://doi.org/10.1007/s12195-020-00629-w>
- [21] H. Salim, and N. A. Jasim "Design and implementation of smart city applications based on the internet of things," *ijim*, vol. 15, no. 3, 2021. <https://doi.org/10.3991/ijim.v15i13.22331>
- [22] S. Sakr and A. Elgammal, "Towards a comprehensive data analytics framework for smart healthcare services," vol. 4, pp. 44–58, 2016. <https://doi.org/10.1016/j.bdr.2016.05.002>
- [23] X. Yuan, C. Yang, Q. He, J. Chen, D. Yu, J. Li, S. Zhai, Z. Qin, K. Du, and Z. J. Chu, "Current and perspective diagnostic techniques for COVID-19," vol. 6, no. 8, pp. 1998–2016, 2020. <https://doi.org/10.1021/acsinfecdis.0c00365>
- [24] A. Al-zubidi, R. K. Hasoun, S. H. Hashim, H Alrikabi, "Mobile application to detect Covid-19 pandemic by using classification techniques: proposed system," *International Journal of Interactive Mobile Technologies*, vol. 15, no. 16, pp. 34–51, 2021. <https://doi.org/10.3991/ijim.v15i16.24195>
- [25] G. Jin, X. Zhang, W. Fan, Y. Liu, P. J. T. O. A. He, and C. S. Journal, "Design of non-contact infra-red thermometer based on the sensor of MLX90614," vol. 7, no. 1, 2015. <https://doi.org/10.2174/1874444301507010006>
- [26] J. Zhang, "Development of a non-contact infrared thermometer," in *2017 International Conference Advanced Engineering and Technology Research (AETR 2017)*, 2018: Atlantis Press. <https://doi.org/10.2991/aetr-17.2018.59>
- [27] O. H. Yahya, H. Alrikabi, and I. Aljazaery, "Reducing the data rate in internet of things applications by using wireless sensor network," *International Journal of Online and Biomedical Engineering (iJOE)*, vol. 16, no. 03, pp. 107–116, 2020. <https://doi.org/10.3991/ijoe.v16i03.13021>
- [28] M. Frei, C. Deb, R. Stadler, Z. Nagy, and A. Schlueter, "Wireless sensor network for estimating building performance," vol. 111, p. 103043, 2020. <https://doi.org/10.1016/j.autcon.2019.103043>

- [29] Q. N. Alsaifi, A. F. Marhoon, and A. Hamad, "Remote patient healthcare surveillance system based real-time vital signs," vol. 16, no. 4, pp. 41–51, 2020. <https://doi.org/10.22153/kej.2020.10.003>
- [30] H. A. Naman, M. Al-dabag, and H. Salim, "Encryption system for hiding information based on internet of things," *International Journal of Interactive Mobile Technologies (iJIM)*, vol. 15, no. 2, 2021. <https://doi.org/10.3991/ijim.v15i02.19869>
- [31] H. Alrikabi, and H. Tauma "Enhanced data security of communication system using combined encryption and steganography," *International Journal of Interactive Mobile Technologies*, vol. 15, no. 16, pp. 144–157, 2021. <https://doi.org/10.3991/ijim.v15i16.24557>
- [32] G. Coulby, A. Clear, O. Jones, F. Young, S. Stuart, and A. J. B. E. O. Godfrey, "Towards remote healthcare monitoring using accessible IoT technology: state-of-the-art, insights and experimental design," vol. 19, no. 1, pp. 1–24, 2020. <https://doi.org/10.1186/s12938-020-00825-9>
- [33] O. H. Yahya, H. T. ALRikabi, R. a. M. Al_ airaji, and M. Faezipour, "Using internet of things application for disposing of solid waste," *International Journal of Interactive Mobile Technologies*, vol. 14, no. 13, pp. 4–18, 2020. <https://doi.org/10.3991/ijim.v14i13.13859>
- [34] H. T. S. ALRikabi, A. H. M. Alaidi, and F. T. Abed, "Attendance system design and implementation based on radio frequency identification (RFID) and Arduino," *Journal of Advanced Research in Dynamical Control Systems*, vol. 10, no. SI4, pp. 1342–1347, 2018.
- [35] N. Petrović and Đ. J. I. B. Kocić, "IoT-based system for COVID-19 indoor safety monitoring," 2020.
- [36] S. Jaafari, A. Alhasani, and S. M. Almutairi, "Certain investigations on IoT system for COVID-19," in *2020 International Conference on Computing and Information Technology (ICCIT-1441)*, 2020, pp. 1–4: IEEE. <https://doi.org/10.1109/ICCIT-144147971.2020.9213760>

7 Authors

Nabaa Ali Jasim, is presently one of the master's students in the college of engineering, Electrical Engineering Department, Wasit University in Al Kut, Wasit, Iraq. She received her B.Sc. degree in Electrical Engineering in 2017 from the Wasit University in Al Kut, Wasit, Iraq. The first was in Electrical Engineering with a grade of very good and the second was in the college of engineering, Wasit University in Al Kut, Wasit, Iraq. Al Kut City- Hay ALRabee. E-mail: nabaaj301@uowasit.edu.iq

Asst. Prof. Haider Th. Salim ALRikabi is presently one of the Faculty College of Engineering, Electrical Engineering Department, Wasit University in Al Kut, Wasit, Iraq. He received his B.Sc. degree in Electrical Engineering in 2006 from the Al Mus-tansiriyah University in Baghdad, Iraq. His M.Sc. degree in Electrical Engineering focusing on Communications Systems from California State University/Fullerton/SA in 2014. His current research interests include Communications systems with the mobile generation, Control systems, intelligent technologies, smart cities, and the Internet of Things (IoT). Al Kut City-Hay ALRabee, Wasit, Iraq. E-mail: hdhiyab@uowasit.edu.iq. The number of articles in national databases – 15, The number of articles in international databases – 40.

Article submitted 2021-10-14. Resubmitted 2021-12-08. Final acceptance 2021-12-10. Final version published as submitted by the authors.