

# Using Remote Labs to Serve Different Teacher's Needs - A Case Study with VISIR and RemoteElectLab

<http://dx.doi.org/10.3991/ijoe.v8iS3.2259>

André V. Fidalgo<sup>1</sup>, Gustavo R. Alves<sup>1</sup>, Maria A. Marques<sup>1</sup>, Maria C. Viegas<sup>1</sup>,  
Maria C. Costa-Lobo<sup>2</sup>, Unai Hernandez<sup>3</sup>, Javier Garcia-Zúbia<sup>3</sup>, Ingvar Gustavsson<sup>4</sup>

<sup>1</sup>Polytechnic of Porto, Porto, Portugal

<sup>2</sup>Universidade Portucalense Infante D. Henrique, Porto, Portugal

<sup>3</sup>University of Deusto, Deusto, Spain

<sup>4</sup>Blekinge Institute of Technology, Karlskrona, Sweden

**Abstract**—Remote Laboratories are an emergent technological and pedagogical tool at all education levels, and their widespread use is an important part of their own improvement and evolution. This paper describes several issues encountered on laboratorial classes, on higher education courses, when using remote laboratories based on PXI systems, either using the VISIR system or an alternate in-house solution. Three main issues are presented and explained, all reported by teachers that gave support to students use of remote laboratories. The first issue deals with the need to allow students to select the actual place where an ammeter is to be inserted on electric circuits, even incorrectly, therefore emulating real world difficulties. The second one deals with problems with timing when several measurements are required at short intervals, as in the discharge cycle of a capacitor. And the last issue deals with the use of a multimeter in DC mode when reading AC values, a use that collides with the lab settings. All scenarios are presented and discussed including the solution found for each case. The conclusion derived from the described work is that the remote laboratories area is an expanding field, where practical use leads to improvement and evolution of the available solutions, requiring a strict cooperation and information sharing between all actors, i.e. developers, teachers and students.

**Index Terms**—Learning Goals, Real-World Scenarios, Remote Labs

## I. INTRODUCTION

A remote laboratory is a type of lab where the experimental apparatus and the user are physically separated, the experiment execution requiring a communication mean (e.g. internet) between user and remote equipment and usually also a specific user interface.

This article describes practical results and experience derived from real world use of remote laboratories on educational environments, listing some of the encountered problems and the solutions that were implemented to solve those issues. The rationale is to provide some operational insight on the practical implementation of remote laboratories and also discuss some ideas on common issues, which weren't evident during system development and implementation.

The described experiments and operational scenarios were used on lab classes on higher education engineering courses at School of Engineering - Polytechnic of Porto, where remote laboratories are used as complement for hands-on laboratories. The issues encountered are both pedagogical and technical and were identified by the teachers responsible for the courses when conducting the remote experiments with students.

Section II describes the pedagogical and technical environment, presenting the remote laboratories and the courses where they are used. Section III gives a more detailed explanation of an in-house solution (i.e. RemoteElectLab) describing the initial implementation, some installation issues and the subsequent system evolution. Section IV describes the issues identified by teachers when using both remote laboratories and also the efforts made to solve these issues. And finally, section V presents the conclusions derived from this process.



## II. BACKGROUND

VISIR is an open remote lab dedicated to experiments with electrical and electronic circuits. It allows teachers and students to practice real-world experiments, remotely and in a real-time mode, with test and measurement equipment (triple DC power supply, function generator, multimeter, and an oscilloscope) of which virtual front panels can be displayed on the user's computer screen. The solderless breadboard is replaced by a relay switching matrix where the components provided are installed. The teachers and students use a virtual breadboard to wire a circuit, i.e. to configure the relays of the matrix connections and the installed components into a desired circuit. The matrix is a stack of boards which also include component sockets or instrument connectors on each board. Thus, the number of online components depends on the number of matrix boards available.

The use of VISIR in a large undergraduate course during the fall (1<sup>st</sup>) semester of 2010/11, at the School of Engineering – Polytechnic of Porto, has already been reported [1, 2], where the main aspects referred and described were: i) references to documents and manuals describing in detail its architecture and technical characteristics [3, 4]; and ii) actions done by persons using it under three different roles (administrator, teacher, student). The study reported in [1, 2] addressed the utilization

of VISIR on a single, large, undergraduate course, where the roles of all actors involved were well defined and, in particular, the head-teacher was able to motivate the lecturing team to the learning activities carried out through VISIR. For instance, all lecturing team elements had the opportunity to practice before using it in their own classes, and everyone was informed about and aligned with the learning goals planned for this complementary lab resource. This scenario contrasts with the spring (2<sup>nd</sup>) semester of 2010/11, where VISIR was used in six different courses, of different sizes (47-to-574 students enrolled) and belonging to six different degrees, i.e. with quite different backgrounds, as described by TABLE I. Furthermore, each head-teacher had the opportunity to define a number of remote experiments – and the associated learning goals. The range of experiments defined by the head-teachers that responded favorably to the challenge of integrating VISIR into their courses implied some negotiation due to intrinsic technical limitations of this remote lab, i.e. the number of matrix boards available is limited to 4 and the time constant of all remote experiments is limited to tens-to-hundreds of milliseconds, depending on the source type – AC or DC. These limitations lead us to suggest the utilization of a complementary remote lab, developed in-house, for more demanding electrical and electronic experiments.

TABLE I.  
TARGET DEGREES/COURSES AND NUMBER OF STUDENTS ENROLLED AND TEACHERS ASSIGNED (+ HEAD-TEACHER)

Degree	Course		
Automotive Engineering (LEMA)	Electricity (ELTRI)	47	2+1
Instrumentation and Metrology Engineering (LEIM)	Applied Instrumentation I (INSA1)	49	1
Computing Engineering & Medical Instrumentation (LECM)	Applied Instrumentation I (INSA1)	68	3+1
Chemical Engineering (LEQ)	Physics (FISIC)	188	2+1
Electric and Computer Engineering (LEEC)	Circuits Theory (TCIRC)	345	6+1
Mechanical Engineering (LEM)	Physics (FISIC)	574	6+1

### III. THE REMOTELECTLAB

RemotElectLab [5] is a more recent remote lab platform for experimenting electric and electronic circuits. It was developed after an analysis of the drawbacks of existing remote lab solutions for the same type of experiments, in an attempt to overcome them, e.g. it was built using a generic hardware platform and it is accessed through a generic interface which does not depend upon the circuit under experimentation. This interface comprehends an oscilloscope, a function generator, a variable DC power source, and two special zones: one for displaying a series of 8 voltage and 8 current readings, and another for controlling a series of switching relays that allow reconfiguring the circuit. The user can identify the node voltages and the branch currents being measured and what configurations he/she can do by analyzing the circuit diagram and i)

matching the voltmeters and ammeters IDs with those appearing in the generic interface; and ii) checking which switches are used and what effect will they have on each possible position. Fig. 1 presents the circuit and switching infra-structure, where, for instance reading V1 on the generic interface corresponds to the effective (measured) circuit input voltage, I1 corresponds to the (measured) current supplied to the circuit by the power source, and, e.g., turning on the switch identified as Address 8 2/2, will select a load resistance of 270  $\Omega$ .

The generic interface of the RemotElectLab has been improved since its initial version 1.0, which initially required the installation of a specific plug-in (LabVIEW Run-Time Engine), at the user side, and the opening of additional ports (other than the standard 80 port), necessary for the client-server interaction. Version 2.0 substituted the LabVIEW plug-in by the Flash Player plug-in, a more generic and common one, with the additional benefit of not requiring other ports than the standard 80 port. This new interface also reduced the download time from 30 seconds to circa 3 seconds [6].

The first implementation of RemotElectLab was based on the National Instruments Educational Laboratory Virtual Instrumentation Suite (NI-ELVIS) I platform, later replaced by the NI-ELVIS II platform in 2009. This implied adapting the Virtual Instruments (VIs) to the new platform, under version 1.0 of the generic interface – a task concluded in August 2010. The new platform requires re-adapting the interface to the new set of VIs, which is still work in progress. The objective is the replication of the initial interface, presented in detail in [5] as it proved to be perfectly matched to the experimental environment.

### IV. SERVING DIFFERENT TEACHERS' NEEDS

The head-teacher of the Electricity (ELTRI) course uses a common electric circuit that is present in diesel-powered cars to illustrate basic electrical voltage-current-resistance-power concepts. The students enrolled in this course have very reduced knowledge of electric circuits and laws, i.e. they have to learn from the scratch, while their motivation can be considered low, given the nature of its degree – automotive engineering – which deals more with mechanics rather than electrical or electronic concepts. Using VISIR with such students can be tricky as some of its inherent technical constraints can be readily explained to persons knowledgeable of electric circuits and test and measurement equipment but difficult to understand by persons learning the basics. The two following figures can be used to partially explain this aspect.

Fig. 2 illustrates the referred circuit, as mounted in RemotElectLab. The first resistor, placed immediately after the DC power supply, can be swapped by a short-circuit, using the controllable relays. The user can also read the measured branch currents and node voltages, this way de-

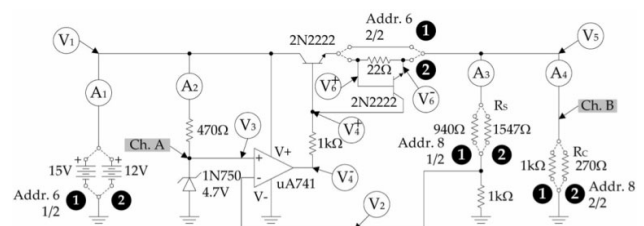

Figure 1. Diagram of a circuit under experimentation, in RemotElectLab

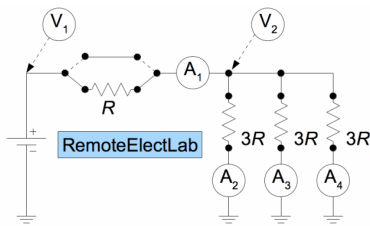

Figure 2. Diagram of a common electric circuit, present in diesel-powered cars, as mounted in RemoteElectLab.

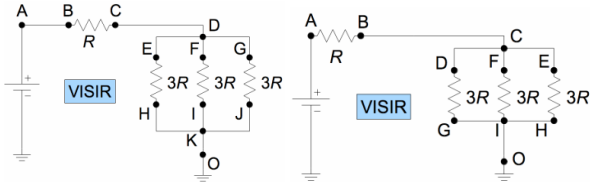

Figure 3. Graphical representation of the same circuit, denoting its (desirable – left, actual – right) implementation in the VISIR matrix.

termining the power dissipated (voltage drop  $\times$  current flow) in each one of the four resistors. Using the measured values, the user can then derive the intrinsic relations between voltage drops and branch currents, using Kirchhoff Voltage Law (KVL) and Kirchhoff Current Law (KCL). This very simple circuit, when mounted in VISIR – while allowing reading the same variables (all voltage nodes and branch currents) – may require as much as 12 nodes (which exceeds the maximum number of nodes usable in the VISIR matrix board, i.e. 10) and more than one entire matrix board, as illustrated in Fig. 3 (left side). Notice that an ammeter needs to be inserted in series with a component (after or before it) in order to measure the electrical current flowing through it. In VISIR, this requires placing a short-circuit between the nodes where the ammeter can be inserted, so as to accommodate the two possibilities, i.e. the ammeter is present or not.

The node voltage measurement possibilities are not represented because VISIR allows connecting the voltmeter – or any oscilloscope channel – to any node, as it corresponds to a high-impedance device. So, reading from Fig. 3 (left side), one needs 13 two-pin components, i.e. 4 resistors and 10 short-circuits (AB, BC, CD, DE, DF, DG, HK, IK, JK, and KO) for implementing this circuit in VISIR. Due to the already mentioned limitation (10 nodes) we decided to still provide the same circuit with a couple of restrictions (see Fig. 3 – right side), i.e. the ammeter cannot be placed “before” the first resistor ( $R$ ) neither “after” the resistor ( $3R$ ) placed in the centre of the parallel network. This means that out of the 9 possible locations the user will receive an “unexpected” error, when placing the ammeter in 2 of them, without a plausible reason for it, as in electrical terms the circuit will be correct. This is a compromise between providing students the ability to experiment that circuit, within the ELTRI course, and not confusing them with details about the technical restrictions of VISIR. An important point to address here is that after discussing this specific circuit with Prof. Ingvar Gustavsson, the mentor of the VISIR system, we were offered an ingenious solution, which we were failing to see in this first analysis [7]. This solution is depicted in Fig. 4, and in a sense it denotes one major aspect around VISIR – the existence of a community of practice that helps facing problems and challenges as the one being discussed here. A brief comparison between the two sol-

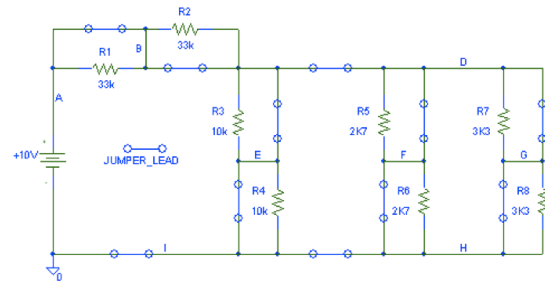

Figure 4. A solution to the problem of measuring all possible individual and total currents in the proposed electric circuit implemented in VISIR.

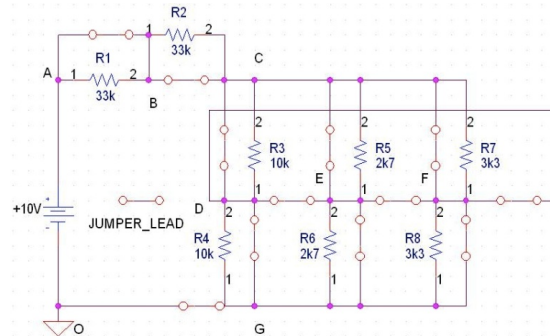

Figure 5. Implementation that allows measuring all individual, 2-parallel and 3-parallel resistor currents in VISIR.

utions indicates however that the later (Fig. 4) implies a total of 8 resistors and 11 short-circuits, i.e. 19 two-pin components, which still does not require more than two component boards.

On a pure conceptual basis, one could extend this simple circuit analysis, by including the possibility to read the current flowing through any two resistors in parallel (see Fig. 5). This increases the number of possible ammeter locations to 15 (before/after each combination of two out of the three resistors in parallel – left/centre, centre/right, and left/right – which gives  $2 \times 3 = 6$  new locations). Extending the circuit diagram depicted in Fig. 4, i.e. adding 3 short-circuits (DE, DF and DE), would also accommodate this new learning goal, as depicted in Fig. 5.

Although not part of the circuit experiment goals, the actual experience of teaching lab courses shows that it is frequent for an inexperienced student, using a breadboard for the first time, to place wires in such a manner that he/she will be making such a measurement, while, at the same time, it may be hard for the teacher to spot the problem on a first glance. This type of “wrong” measurements should be possible in remote laboratories so that students can see the consequences of incorrect measurements and learn from their mistakes. If the remote laboratory implementation doesn’t allow mistakes which are common on real labs, or signals them as system errors, it is providing an non-intended assistance to the students and failing on the objective of replicating the real lab conditions. This aspect is clearly demonstrated through Table II, which presents all possible circuit current measurements in terms of individual, 2-parallel, and 3-parallel resistors. Notice in the last row of table II that we opted to place the 3-parallel resistors in a horizontal position just to illustrate and stress out the sort of layouts students can implement and teachers need to debug when something is not working as expected.

TABLE II.  
MEASURING ALL INDIVIDUAL, 2-PARALLEL, AND 3-PARALLEL RESISTOR CURRENTS IN THE CIRCUIT UNDER ANALYSIS.

$I_{R1}$	DC Power Supply +25V COM -25V +6V GND	Function Generator GND	Oscilloscope Ch1 Ch2 V/Ohm mA	DMM V/Ohm mA
$I_{R2}$	DC Power Supply +25V COM -25V +6V GND	Function Generator GND	Oscilloscope Ch1 Ch2 V/Ohm mA	DMM V/Ohm mA
$I_{R3}$	DC Power Supply +25V COM -25V +6V GND	Function Generator GND	Oscilloscope Ch1 Ch2 V/Ohm mA	DMM V/Ohm mA
$I_{R4}$	DC Power Supply +25V COM -25V +6V GND	Function Generator GND	Oscilloscope Ch1 Ch2 V/Ohm mA	DMM V/Ohm mA
$I_{R23}$	DC Power Supply +25V COM -25V +6V GND	Function Generator GND	Oscilloscope Ch1 Ch2 V/Ohm mA	DMM V/Ohm mA
$I_{R34}$	DC Power Supply +25V COM -25V +6V GND	Function Generator GND	Oscilloscope Ch1 Ch2 V/Ohm mA	DMM V/Ohm mA
$I_{R24}$	DC Power Supply +25V COM -25V +6V GND	Function Generator GND	Oscilloscope Ch1 Ch2 V/Ohm mA	DMM V/Ohm mA
$I_{R234}$	DC Power Supply +25V COM -25V +6V GND	Function Generator GND	Oscilloscope Ch1 Ch2 V/Ohm mA	DMM V/Ohm mA

A single schematic representation may be implemented in many different ways, in a breadboard, which makes it so difficult for students to visualize and understand the relationship between a breadboard layout and a circuit diagram and for teachers to diagnosis mismatches, in a typical lab session – even with a small number of components, as it is the case in the present scenario. Again, this raises the question of adding an intelligent tutor system for VISIR that would provide online support for such a type of problems. On the technical side it would also been possible to solve the problem by using a different type of relay matrix, i.e. such as the one described in [7], which allows an increased number of connections, comparing to the one currently allowed by the PXI-based version of VISIR.

On a different situation, the head-teacher of the Circuit Theory (TCIRC) course (LEEC degree) requires students

to understand the dynamic behavior of both capacitors and coils when powered by a DC source. The problem lies on the fact that the time constant of such a circuit may well be beyond the time duration of a typical experiment done in VISIR. For instance, a circuit comprising a 10 kΩ resistor in series with a 220 μF capacitor will have an RC time constant of 2.2 seconds which is beyond the 50-100 milliseconds that takes to complete a VISIR experiment in DC mode, with the oscilloscope [8]. Additionally, this experiment is done in the real lab, where students have to measure the voltage drop across the capacitor, each Δt seconds, note down and produce a graph with those values, in an Excel worksheet, so as to see the exponential form of a capacitors charge curve, as defined by the capacitor equation (1). The remote version of this experiment was implemented in a different RemoteElect Lab version developed as part of the PhysicsLabFARM project and customized for this specific problem. The interface was adapted to this specific task and the experiment was made available to students through the course Moodle page, later in the semester, i.e. in the very last week of classes. Until the end of the semester, this resource was accessed over 40 times, mainly just out of students' curiosity.

$$V_C = V_{DC} \cdot (1 - e^{-\frac{t}{RC}}) \quad (1)$$

The sequence of actions to run this experiment is illustrated in the following figures. Fig. 6 illustrates the entry page, which provides a general description of the capacitors and coils charge experiments. Fig. 7 illustrates the circuit under experimentation, where users can select – among a limited number of available options – the DC input value, the resistors value, and the capacitors value. Once the configuration is complete the user may “submit” it to perform the experiment. To give an example, fig. 8 illustrates the selection process referred to the capacitors value. Fig. 9 illustrates the message box displayed, indicating the time remaining until the remote experiment is concluded.

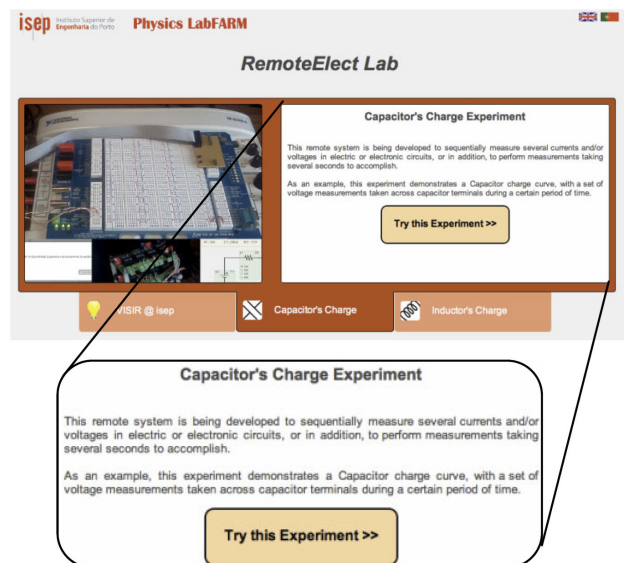

Figure 6. Entry page, for the PhysicsLabFARM project's Capacitor Remote Experiment.

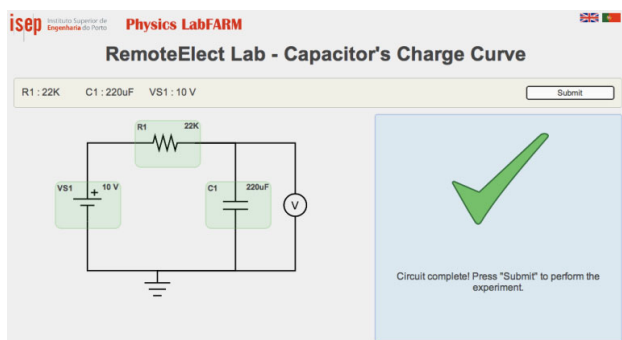

Figure 7. The circuit under experimentation denoting the configurable elements.

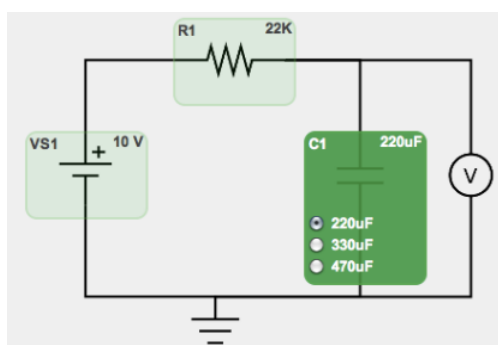

Figure 8. Selecting one out of three capacitors inserted in the relay matrix.

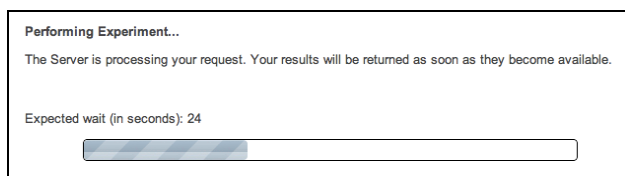

Figure 9. Message box while the experiment is being remotely done.

Results																					
Δt = 1200 ms																					
t	0	Δt	2 Δt	3 Δt	4 Δt	5 Δt	6 Δt	7 Δt	8 Δt	9 Δt	10 Δt	11 Δt	12 Δt	13 Δt	14 Δt	15 Δt	16 Δt	17 Δt	18 Δt	19 Δt	20 Δt
V	-0.000	3.001	4.604	5.825	6.760	7.477	8.029	8.456	8.786	9.042	9.241	9.396	9.517	9.611	9.685	9.743	9.789	9.825	9.853	9.876	9.893

Figure 10. Page displaying the remote experiment results.

The total time will depend upon the total RC time constant – respecting the users' configuration – being in the range of a few to several tenths of seconds. Finally, Fig. 10 illustrates the page region presenting the remote experiment results, i.e. the voltage drop measured at the capacitors terminals, every  $\Delta t$  – as defined by the experiment – so that at  $20 \cdot \Delta t$ , the capacitors voltage should be at approximately 99% of the DC input value, according to (1).



A third situation was also reported in the TCIRC course, on the VISIR system, and is an interesting issue to be addressed both by the system developers and users. The methodology behind the VISIR system assumes that all experiments should be performed as fast as possible, so that the resources are up and ready to be used most of the time, i.e. providing high availability. To achieve this, each experiment is powered up for the least amount of time and meter readings are assumed to be almost instantaneous. In this course, the number of students is substantial so ex-

periment timings were trimmed to their lowest value for some apparently simple experiments, requiring only the measurement of AC and DC voltage values. One specific request was the measurement of the DC voltage of an AC sinusoidal waveform, i.e. its DC bias. It was reported by the teacher that the multimeter readings for DC voltage of sinusoidal waves (from a signal generator) were wrong most of the time and results varied considerably between similar experiments. It was verified that the wave was correct (by the remote oscilloscope), that the AC voltage was read correctly and that the DC multimeter readings were always between the limit voltages of the sinusoidal wave (they should read zero instead). Table III represents the measurements obtained with a sinusoidal wave with 1 Vpp.

Further study of the issue, using a square wave, showed that the values would either be measured as the maximum or minimum values. It was decided to test the same circuit on a real laboratory, using similar equipment to the remote environment, and although the results were different, i.e., the multimeter returned the correct value, it was evident that it took some time for the reading to stabilize on the correct value. Due to the internal operation of the multimeter, there is a relevant delay until the actual average value is read, during which the multimeter displays what seems to be instantaneous voltage values. This fact is due to the need for at least a full period of the wave under analysis to be read, plus processing time, before an accurate reading of average or RMS values is possible.

The VISIR system uses different delays (defined by the PXI system requirements) when measuring AC or DC values, these being considerably higher for AC (50 ms for AC vs. 10ms for DC) in order to cope with the higher measurement time. However, when trying to measure DC values on AC signals the delay is insufficient and the returned values are representative of the initial adjustment cycle visible on real multimeters. Although apparently trivial, this issue proves that some remote laboratory settings can interfere with experiment results, mostly when time is a relevant issue. The need for high availability, requiring very fast experiments, must be weighted against possible induced errors, depending on the experiment itself. In this case there are some solutions that can be applied immediately at different levels, namely it is possible to increase the experiment time and accept lower availability or modify the experiment (increasing the frequencies for instance) to get lower response time. At a higher level, it is possible to use faster multimeters and/or optimize the VISIR system itself.

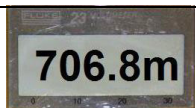
TABLE III.  
MEASURING ALL INDIVIDUAL, 2-PARALLEL, AND 3-PARALLEL RESISTOR CURRENTS IN THE CIRCUIT UNDER ANALYSIS.

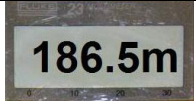
AC Voltage (RMS) Measurement	
1 <sup>st</sup> DC Voltage Measurement	
2 <sup>nd</sup> DC Voltage Measurement	

## V. CONCLUSION

Remote laboratories are presently being regarded as a complementary approach to hands-on laboratories within different learning levels and goals. Nevertheless and since they are developed in order to reproduce the same performance as real experiments and equipment, an extended set of experimental testing scenarios is of extreme importance. Even so, as demonstrated with VISIR, an internationally wide spread remote laboratory, this purpose may not be fully accomplished, since new situations can arise. Some of them can be solved, within the system, but other may imply a change in the system architecture.

The existence of a wide and active VISIR community is a major advantage and provides momentum to the system evolution and improvement. The users, both teachers and students, often come up with different requirements, or identify problems which weren't anticipated by developers. This feedback is often used to add new features, improve system interface and operation and clarify methodologies.

Alternatively, some experiments require specific and customized solutions that, for now, are beyond the VISIR scope. The described multilevel approach was developed so that the proposed remote laboratories usage objectives were accomplished and most issues were solved. On most cases, the remote laboratory was able to replicate hands-on experiment effectively and with ease. Some cases, mostly the ones listed in this document, some experiment adaptation and tweaking was required and, on a few cases, the actual experiment or the remote lab had to be altered.

As it is often said in military, "no battle plan survives contact with the enemy", and this is also true for experimentation in general and remote labs in particular. The described experiments show that once users start experimenting, some bugs and issues are bound to occur. It is up to the support infrastructure to handle them, assuring that the end users get what they expect, namely an operational and useful laboratory.

## REFERENCES

- [1] G. R. Alves et al., "Using VISIR in a large undergraduate course: Preliminary assessment results", Proceedings of the 2nd IEEE Engineering Education Conference (EDUCON'11), Amman, Jordania, 4-6 April 2011, pp. 1125-1132.
- [2] M. C. Costa Lobo et al., "Using VISIR in a large undergraduate course: Initial findings," Proceedings of the 2011 Frontiers in Education Conferences (FIE'11), 41st Edition, Rapid City, South Dakota, US, 12-15 October 2011.
- [3] I. Gustavsson et al., "A Flexible Electronics Laboratory with Local and Remote Workbenches in a Grid," International Journal of Online Engineering (iJOE), 2008. vol. 4, nr 2, pp. 12-16.
- [4] I. Gustavsson et al., "On Objectives of Instructional Laboratories, Individual Assessment, and Use of Collaborative Remote Laboratories," IEEE Transactions on Learning Technologies, Oct.-Dec. 2009, vol. 2, pp. 263-274. <http://dx.doi.org/10.1109/TLT.2009.42>
- [5] Nuno Sousa, Gustavo R. Alves, and Manuel G. Gericota, "An Integrated Reusable Remote Laboratory to Complement Electronics Teaching," IEEE Transactions on Learning Technologies, July-Sept. 2010, Vol. 3, nr. 3, pp. 265-271, ISSN: 1939-1382, <http://dx.doi.org/10.1109/TLT.2009.51>.
- [6] Pedro J. Teixeira, "Building Flex Interfaces for Remote Experimentation Systems", Master Thesis, School of Engineering – Polytechnic of Porto, Portugal, September 2010, p. 109. [Construção de Interfaces em Flex para Sistema de Experimentação Remota, Tese de Mestrado, Instituto Superior de Engenharia do Porto].
- [7] I. Gustavsson, "On Remote Electronics Experiments", Using Remote Labs in Education, University of Deusto, Bilbao, 2011, pp. 157-176
- [8] J. García-Zubía, U. Hernández-Jayo, I. Angulo, D. López-de-Ipiña, P. Orduña, J. Irurzun, O. Dziabenko, "LXI Technologies for Remote Labs: An Extension of the VISIR Project," iJOE – Volume 6, Special Issue 1: REV2010, September 2010, pp. 25-35.

## AUTHORS

**A. V. Fidalgo, G. R. Alves, M. A. Marques, and M. C. Viegas** are with the School of Engineering – Polytechnic of Porto, Rua Dr. Antonio Bernardino de Almeida, 431, 4200-072 Porto, Portugal (e-mail: {anf, gca, mmm, mcm}@isep.ipp.pt).

**M. C. Costa-Lobo** is with Universidade Portucalense Infante D. Henrique, Rua Dr. António Bernardino de Almeida, 541, 4200-072 Porto, Portugal (email: ccostalobo@upt.pt).

**U. Hernandez** is with the Faculty of Engineering, University of Deusto, Bilbao, 48007 Bilbao, Spain (e-mail: unai.hernandez@deusto.es).

**J. García-Zubía** is with the Industrial Technologies Department, University of Deusto, Avda. Universidades 24, 48007 Bilbao, Spain, (e-mail: zubia@deusto.es).

**I. Gustavsson** is with the Electrical Engineering Department, Blekinge Institute of Technology, SE-37179 Karlskrona, Sweden, (e-mail: ingvar.gustavsson@bth.se).

This article is an extended and modified version of a paper presented at the International Conference on Remote Engineering & Virtual Instrumentation (REV2012), held at University of Deusto, Bilbao, Spain, July 4-6, 2012. Manuscript received 14 September 2012. Published as resubmitted by the authors 14 November 2012.