

Virtual Instruments for the Circuit Analysis with Interactive Parameter Modification

E. Brenner

University of Applied Sciences Dresden/Faculty of Electrical Engineering, Dresden, Germany

Abstract—The contribution presents the possibilities of LabVIEW in the special application as formula interpreter by using of the formula node. The main advantage is the immediate presentation of results in case of a parameter modification. The presentation of the time behaviour, the calculation of characteristic values and curves for typical examples of power electronics and control engineering are shown.

Index Terms—Education, Formula Interpretation, LabVIEW, Power Electronics, Virtual Instruments

I. INTRODUCTION

An essential goal in the education of engineering students is a better and faster understanding for complex technical tasks. For the basic education in field of power electronics it concerns the characteristics of power electronic devices and the static and dynamic behaviour of line- and self-commutated converters.

You can describe the different functional connections by means of linear or non-linear equation or equation systems. The interpretation of these equations is often not so easy, above all in case of complex parameter combinations.

The consideration of parameter changes by the application of normal simulation programs requires a multi-simulation, i.e. more than one simulation run. Normally it is also not possible to make any analysis in a parallel process simultaneously.

First the contribution presents the possibilities of the graphic programming system LabVIEW, which can be applied above all for measuring tasks. LabVIEW is a program package with an object-oriented graphic programming language. The development of application programs is carried out by an operating surface and by using of graphic software modules, named Virtual Instruments (VI), which are connected together. Each VI consists of a Front Panel (control elements, indicators and graphs) and a Block Diagram (program architecture with functions and routines). The connection of some VI's (Sub-VI's) to one VI allows a solution of complex tasks [1, 2, 3]. LabVIEW has a powerful formula node and the ability for numeric and graphic presentations.

Each parameter can be arranged on the Front Panel, e.g. by means of a slider or numeric control and can be modified in the agreed limit values. The results of the interpretation can be displayed in different way, e.g. as:

- time behaviour of voltages, currents, power components and so on
- relevant numeric characteristic values
- relevant graphic curves

The immediate announcement of the numeric and/or graphic results by the on-line modification of equation parameters is the essential advantage of this solution. On the basis of the interpretation results further analysis can be carried out, e.g. a harmonic analysis.

II. FORMULA INTERPRETATION WITH INTERACTIVE PARAMETER MODIFICATION

A. Common basics

The mathematical task consists of solution and analysis of equations for the steady state mainly, e.g. for the load current of a rectifier. But the calculation of transient behaviour (from period to period) can be also carried out. After that it is easy to calculate the further interesting currents or voltages.

Electronic devices can be agreed as ideal switches, i.e. in the equation(s) are not considered any static or dynamic features.

Each Front Panel (e.g. fig.1) consists of a control panel (left) and a panel for the display of the calculation results (right). After the program start the basic setting of the VI will be activated. This setting allows by means of a program ring to arrange a setup (number and grouping of diagrams, auto-scaling for x-axis and y-axis or the agreement of desired minimum/maximum limits for the ordinate of each diagram, arrangements for an automatic parameter change etc.). Extensive presentations can be allocated on several pages.

As a function of the concrete tool some specific subprograms (e.g. for Fourier analysis, calculation of numeric characteristics, generation and display of characteristic curves) can be called up single buttons. In the lower area of the control panel you can see the sliders and numeric controls for these parameters, which have been extracted and which can be changed in this way.

In the basic state of the tool the calculation and the immediate presentation of the time behaviour will be carried out. The relevant curves can be assigned to the single diagrams freely eligible. Each diagram has a legend, which can be faded in or out. It is also possible to change different curve parameters (e.g. line colour, type or thickness) by using of the legend.

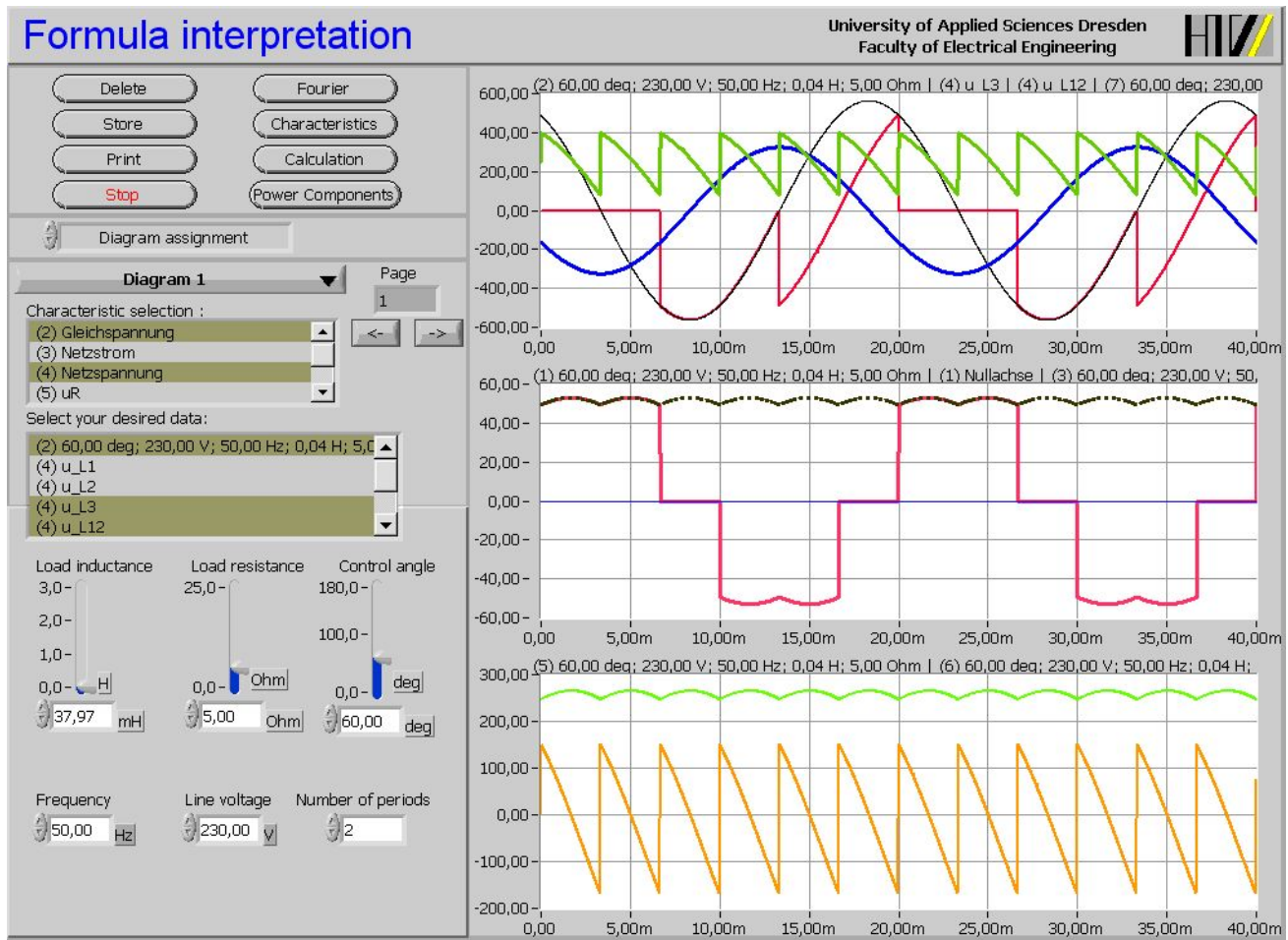

Figure 1. Voltage and current curves of a full-controlled B6-rectifier

B. FI-Tools: p-pulses rectifiers [4]

Separate tools have been developed for single- and three-phase rectifiers for reasons of the clearness of the programming. In both tools the common structures of rectifiers (uncontrolled, full- and half-controlled) with and without free-wheeling diode can be selected. The selection of an ohmic, ohmic-inductive, ohmic-capacitive and motor load as well as the load with an additional or back voltage is possible. Besides the influence of the line inductance and line resistance can be considered. The generation of the control signals is based on the principle of the phase-angle control.

Fig. 1 shows typical voltage and current curves of a full-controlled three-phase bridge rectifier circuit by an ohmic-inductive load. Variable equation parameters are the load parameters and the control angle as well as the parameters of the supply voltage. In this way the influence of the load, the control and the commutation process can be investigated.

A further advantage is given with the execution of a Fourier analysis (fig. 2). Two freely eligible quantities (e.g. direct voltage and power-line current in fig. 2) can be analysed simultaneously. The direct effects on the

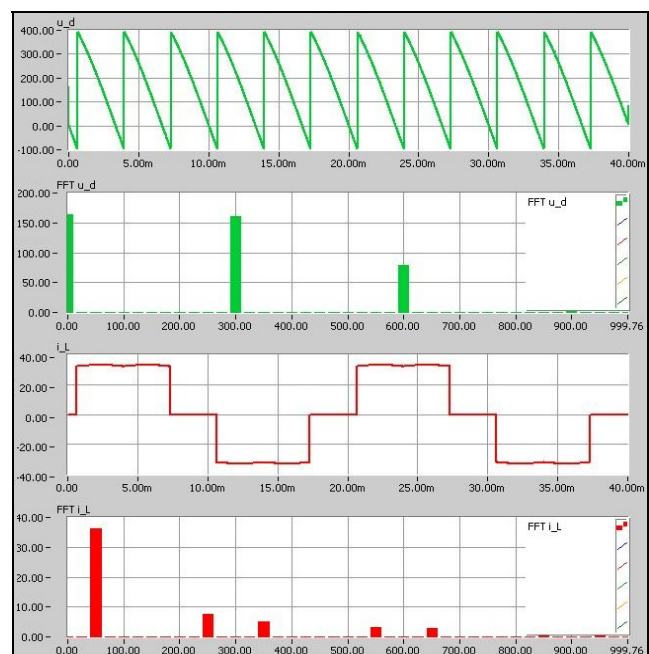

Figure 2. Results of a Fourier analysis of a full-controlled B6-rectifier

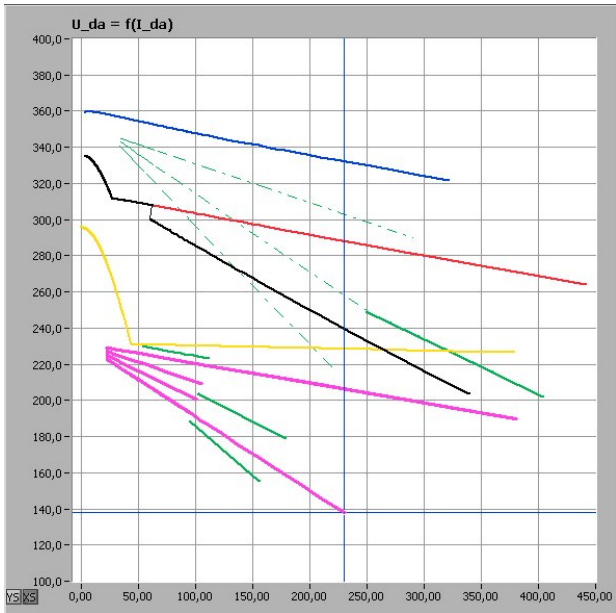

Figure 3. Generation of different load characteristics

spectrum of oscillations by modification of control and load parameters can be observed.

Different subprograms allow the calculation of numerical characteristics in a parallel operation. In this way selected curves can be generated. Average, RMS and maximum values and further numerical characteristics (e.g. ripple factor, fundamental and harmonic oscillation content) or time differences can be also displayed in freely eligible dependencies.

Fig. 3 shows e.g. a part by the generation of load characteristics (transition from discontinuous to non-discontinuous current) by variation of the firing angle in that case. An automatic, but also manual generation (with the highest flexibility) of curves is possible.

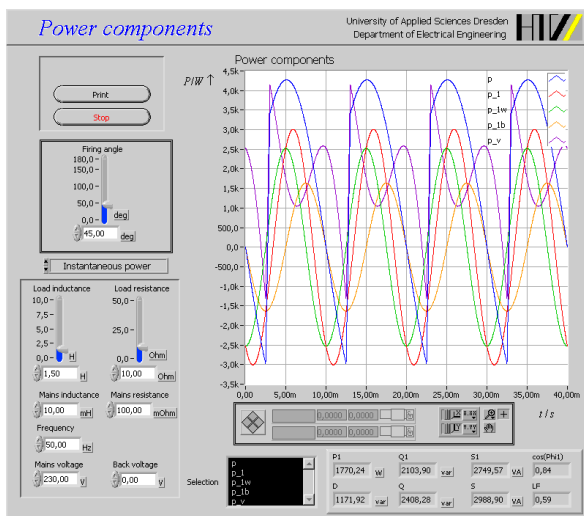

Figure 4. Presentation of selected instantaneous power components (2-pulse controlled rectifier with ohmic-inductive load)

The instrument allows further an investigation of the various power components and is based on the Fourier analysis of the main voltage and the power-line current. Thus the active, reactive and apparent power components for the fundamental oscillation and the harmonics are calculable. The results can be presented as power curves, phasor diagrams, locus diagrams or as instantaneous power components (fig. 4). The effects in the various power components trough an interactive modification of load, control and line parameters can be observed and interpreted also in this example.

C. FI-Tool: DC choppers [5]

In the new current version of this tool the circuit of the investigating assembly has been integrated in the control panel. In this case the sliders for the parameters have been placed near to the device/control components. This tool allows the analysis of dc choppers as buck and boost converters with pulse-width and pulse-frequency modulation as well as the two-position-control. The ohmic, ohmic-inductive load or a dc motor can be selected as load.

In fig. 5 the circuit of a boost converter with eligible pulse-width or pulse-frequency modulation is shown. The circuit of a two-quadrant chopper for resistance braking with current reverse is shown in fig. 6.

Fig. 7 shows the Front panel of this tool in case of a buck converter by ohmic-inductive load. The sliders T respectively T_E allows the investigation by pulse-frequency and pulse-width modulation. Three sliders for the selection of start time, the time range and the history range have been placed in the lower field of the operation panel. The display panel at the right hand side contains the selected diagrams, where the curves can be allocated freely eligible. In the three diagrams (fig. 7, right) you can see the in- and output- voltage as well as the switch voltage, the load current by pulse-width modulation and

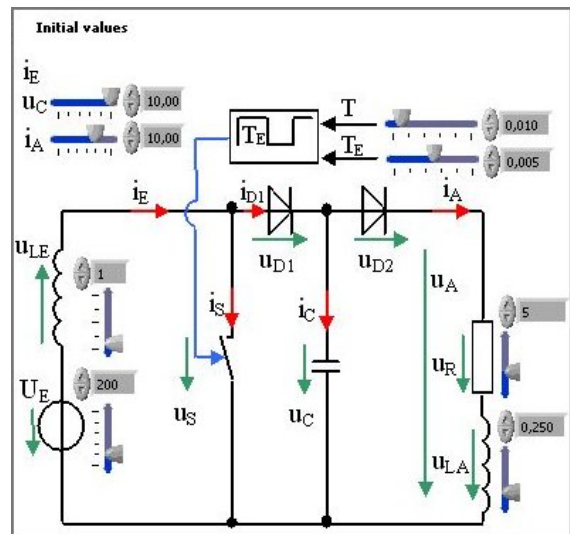

Figure 5. DC boost converter with pulse-width or pulse-frequency modulation

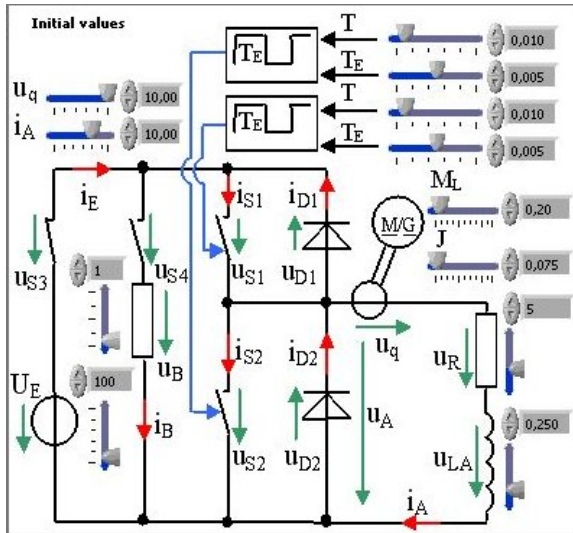

Figure 6. DC converter for the resistance braking with current reserve

finally the voltage drop of the load resistance and load inductance.

Below the diagrams you can see some bar graph charts for the display of characteristics. In this way the duty cycle, the time period, the turn-on and turn-off time as well as the current time constant can be observed.

The right bar graph chart shows the average and RMS value of the output- voltage and -current as well as the the active power in the current operating point.

D. FI-Tools: Voltage fed inverters [6]

This tool is suitable for the calculation and display of the voltage and current relations of single- and three phase voltage-fed inverters. The block or sine-wave control can be selected as control method.

Fig. 8 shows the Front Panel of the visualisation tool for a single-phase voltage-fed inverter by application of a sine-wave control method. Variable parameters are the input voltage, output frequency as well as the values for load resistance and load inductance in that case. They can be modified by means of the sliders. The other variable parameters are the amplitude and frequency of the sine-shaped reference voltage u_{Ref} and the triangular control voltage u_{St} , which can be changed by means of numeric controls.

In the lower part of the control panel a numeric display is arranged for typical characteristics. The example shows the maximum and RMS value of the load current, the RMS value of the intermediate circuit voltage and the load voltage, the power factor, the duration cycle as well as the active and apparent power.

In the diagrams are shown typical curves by using of the sine-wave control method. Diagram 3 in fig. 8 shows e.g. the curve of the load current by ohmic-inductive load for two different cases, i.e. different time constants.

Each of the curves in each diagram can be single stored or deleted. The effects of the modification of one parameter ore several parameters on the single displayed curves are visible in all the diagrams simultaneously.

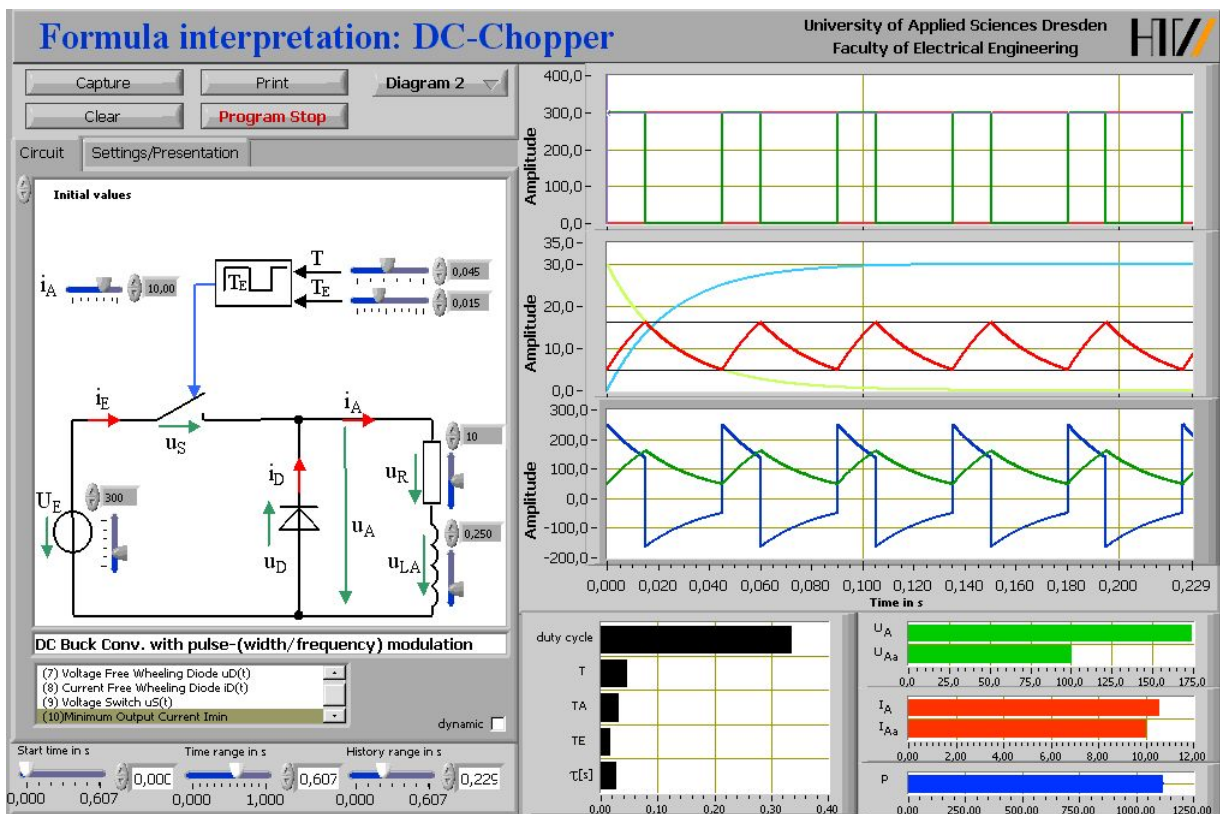

Figure 7. Front Panel of the FI-Tool for the analysis of different dc choppers (e.g. buck converter with ohmic-inductive load)

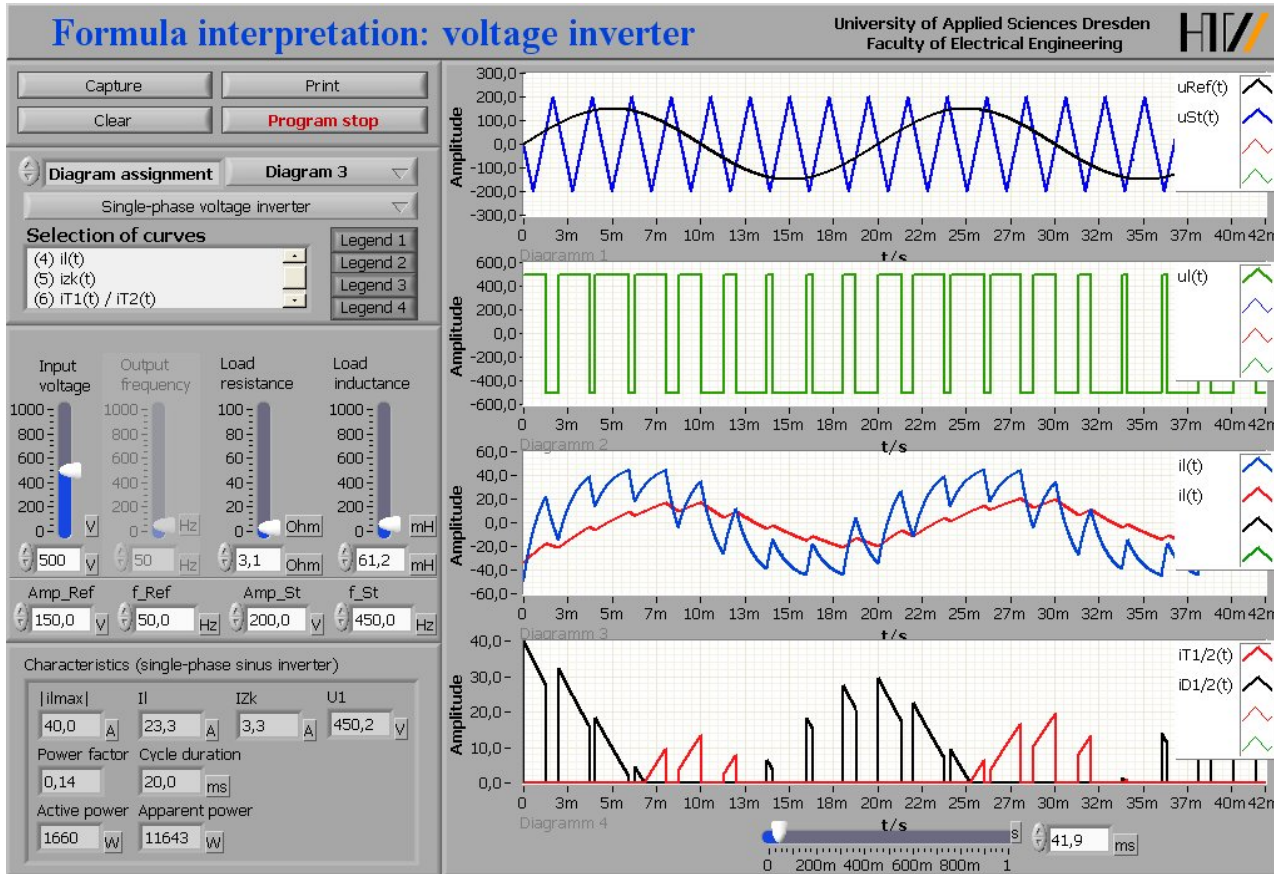

Figure 8. Formula interpretation with interactive parameter modification for the investigation of a single-phase voltage fed inverter

Below the diagrams a further slider is arranged for changes of the time axis (sweep magnification / compression).

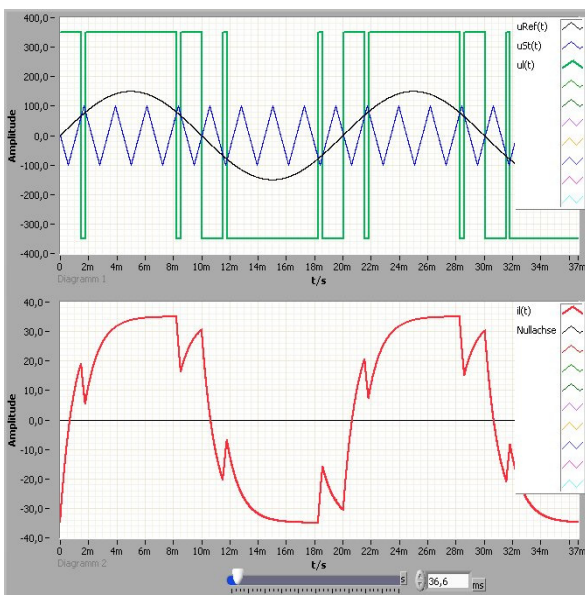

Figure 9. Voltage and current of a single-phase inverter in case of overmodulation

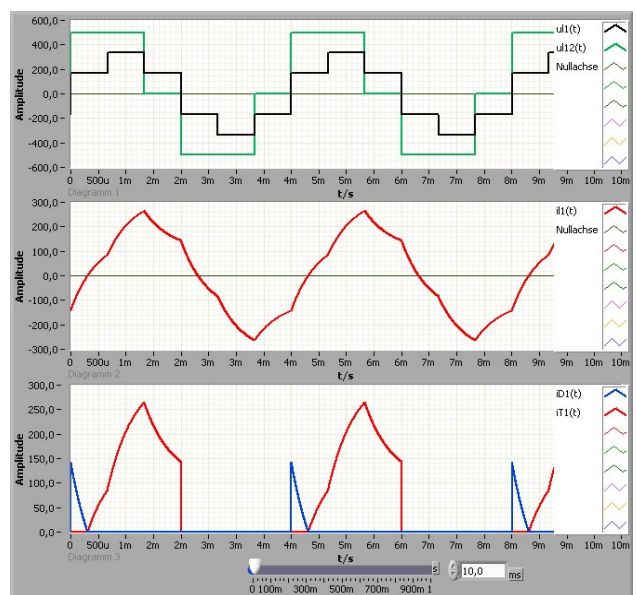

Figure 10. Selected curves of a three phase inverter for block control

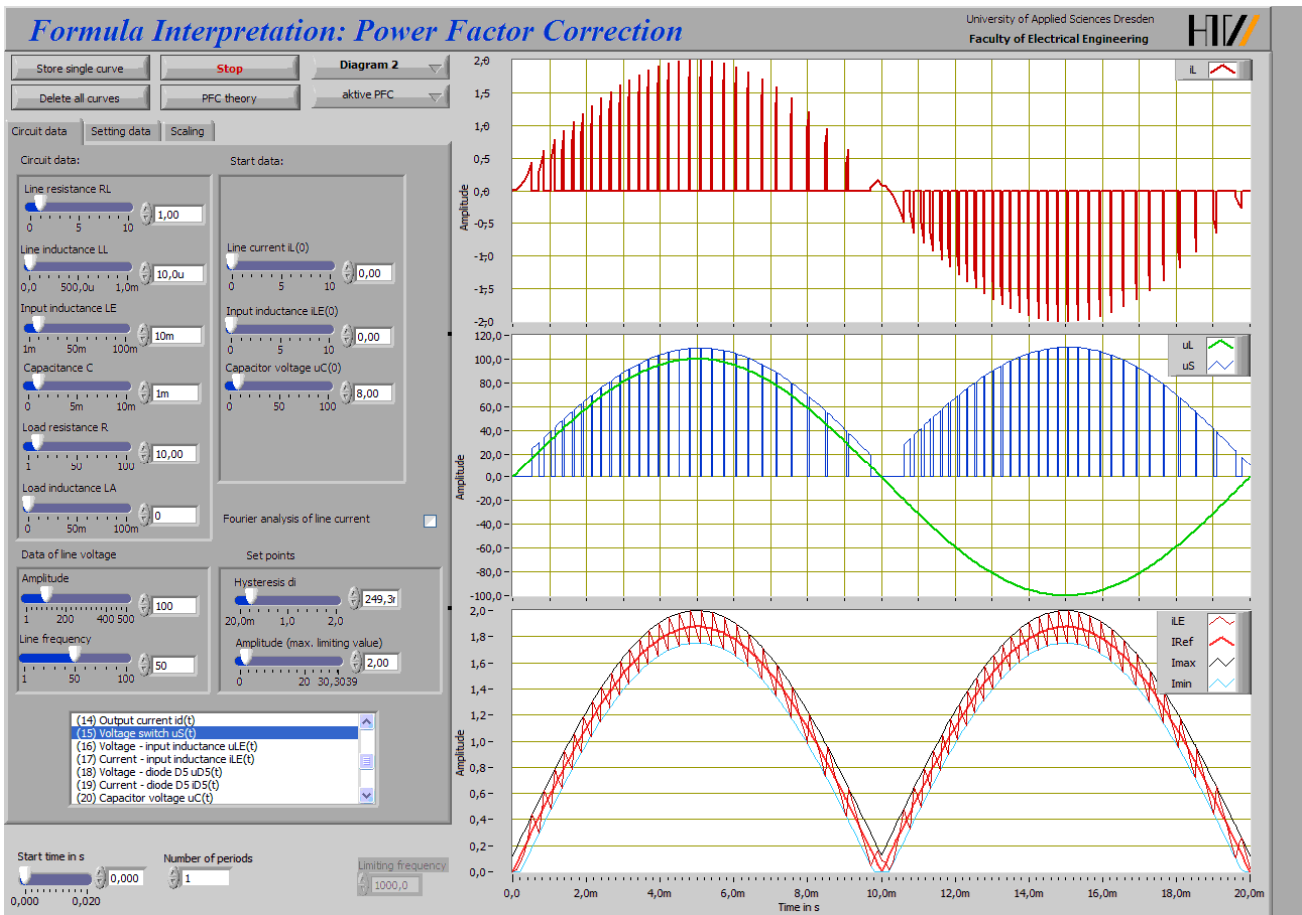

Figure 11. Front Panel of the FI-Tool “Power Factor Correction”

D. FI-Tools: Power Factor Correction

Fig. 11 shows the Front Panel of this FI-Tool. The VI allows the investigation of the passive and active power factor correction for single phase applications. The basic circuit is the combination of an uncontrolled 2-puls-rectifier with an invers boost converter. The function principle based on the two-position-control of the current trough the inductance of the boost converter i_{LE} (fig. 11). The essential default parameter is the desired hysteresis of this current.

The reduction of the hysteresis produces a better approximation to the sine-shaped reference current i_{Ref} and because of this a reduction of the harmonics.

The modification of essential line and circuit parameters as well as control parameters (e.g. current hysteresis) is possible by means of this tool. Further you can agree different start values for the efficient calculation of the steady state.

A special Sub-VI allows the analysis of the line current (amplitude and phase angle) in the range of the investigated frequencies. The relevant voltages and currents of the line and the circuit can be selected and displayed.

III. CONCLUSIONS

In this contribution some analyzation tools for the formula interpretation with interactive parameter modification by using of LabVIEW are presented. In particular, FI instruments for the investigation of p-pulses rectifiers, dc choppers, single- and three-phase voltage-fed inverters and for the Power Factor Correction are described. The comparison between the results of this calculation and in another way founded results, e.g. by simulation with SIMPLORER or MATLAB, has shown a good conformity [7].

The named examples for the FI instruments are used for demonstrations in lectures as well as in theoretical and practical exercises of power electronics basic courses. However the main advantage by application of these tools is given by the autonomous handling trough the students themselves. The advantage of a better understanding, connected with a saving of time, will be viewed as special favourably.

REFERENCES

- [1] Brenner, E.: Virtual Instruments for Measuring Tasks on Power Electronics. *EPE '99, DS 2.11 "Measurement and Sensors"*, p. 1 – 10, Lausanne, 1999
- [2] Brenner, E., Jany, M.: LabVIEW – Harmonic and Power Analyzer. *EPE'01, L2c, "Measurement and Sensors – Software for measurements and virtual instruments"*, Graz, 2001
- [3] Brenner, E., Koßyk, P.: Virtuelle Instrumente in der Leistungselektronik. *Zeitschrift der Hochschule für Technik und Wirtschaft Dresden (FH)*, H. 2, 2002, Dresden, S. 110 - 122
- [4] Arlt, L.: Online-Interpretation von ausgewählten Formeln der Leistungselektronik unter Nutzung des grafischen Programmiersystems LabVIEW. *HTW Dresden, Fachbereich Elektrotechnik*, Diplomarbeit, Dresden, 2002
- [5] Gießmann, A.: Visualisierungstools auf der Grundlage von Formelinterpretation mit interaktiver Parameteränderung für selbstgeführte Stromrichter unter Nutzung von LabVIEW. *HTW Dresden, Fachbereich Elektrotechnik*, Masterarbeit, Dresden, 2004
- [6] Großkopf, G.: Online-Formelinterpretation unter Nutzung des grafischen Programmiersystems LabVIEW zur Analyse des Betriebsverhaltens ausgewählter Schaltungen der Leistungselektronik. *HTW Dresden, Fachbereich Elektrotechnik*, Master-Projektarbeit, Dresden, 2003
- [7] Brenner, E.: Formula Interpretation and Simulation with Interactive Parameter Modification in Field of Power Electronics. *EPE-PEMC '04, S. 4-494 – 4-501, Riga*, 2004

AUTHOR

Eberhard Brenner is with the University of Applied Sciences Dresden, Faculty of Electrical Engineering Friedrich-List-Platz 1, 01069 Dresden, Germany (e-mail: brenner@et.htw-dresden.de)